



## ADC AD50V TUMBLE DRYER



### MODELS:

ADC AD-30V

### DIMENSIONS:

HxWxD: 1720x870x1830mm

### CAPACITY:

23kg

#### IDEAL FOR:



PUBLIC SECTOR



INDUSTRIAL

### FEATURES:

- ▶ 18.30 cu ft basket volume
- ▶ 150,000 Btu/hr heat input, 750 cfm airflow
- ▶ Radial airflow
- ▶ Steel door with gasketless glass
- ▶ Easy access to lint compartment
- ▶ Fits through a standard 30" door
- ▶ Available in gas, steam and electric heat
- ▶ Self-diagnostic microprocessor

### SAFETY SYSTEMS

- ▶ S.A.F.E Sensor Activated Fire Extinguishing System - We've eliminated fire concerns with our patented S.A.F.E. system that automatically senses a fire condition, immediately dispenses water to extinguish it, then shuts itself down, eliminating water damage and cleanup.

**ONECARE<sup>cc</sup>**

This machine is eligible for our all inclusive service solution, One Care.

**AD-50V**

Application features		
Tumbler Capacity (dry weight)	kg (lb)	50 (22.68)
Tumbler Diameter	inches (cm)	32-3/4 (83.19)
Tumbler Depth	inches (cm)	37 1/2 (92.25)
Tumbler Volume	cu ft (litres)	18.30 (518.20)
Tumbler/Drive Motor (nonreversing/reversing)	hp (kW)	3/4 / 1/2 (0.56 / 0.37)
Blower/Fan Motor (nonreversing/reversing)	hp* (kW)	-- / 1/2 (0.37)
Door Opening (Diameter)	inches (cm)	21-1/2 (54.61)
Door Sill Height	inches (cm)	33-1/8 (84.15)

Water connection		
S.A.F.E. Water Connection	inches	3/4

Dimensions		
Width	mm	870
Depth	mm	1264
Height (Gas Model)	mm	1830
Height (Electric Model)	mm	1910
Airflow - gas/electric/steam 50 Hz	cfm	625
Exhaust Connection	inches	8

Connection					
<b>GAS MODEL***</b>	Approx. Net Wt.	lbs (kg)	651 (295.25)		
	Approx. Ship Wt.	lbs (kg)	700 (317.51)		
	Heat Input	Btu/hr (kcal/hr)	150,000 (37,799)		
	Inlet Pipe Connection	inches	1/2 B.S.P.T. (CE and Australia Only)		
<b>ELECTRIC</b>	Approx. Net Wt.	lbs (kg)	651 (295.25)		
	Approx. Ship Wt.	lbs (kg)	700 (317.51)		
	Exhaust Connection	inches (cm)	8 (20.32)		
			kW	Btu/hr	kcal/hr
			20	68,200	17,200
		24	81,900	20,600	
		30	102,400	25,800	

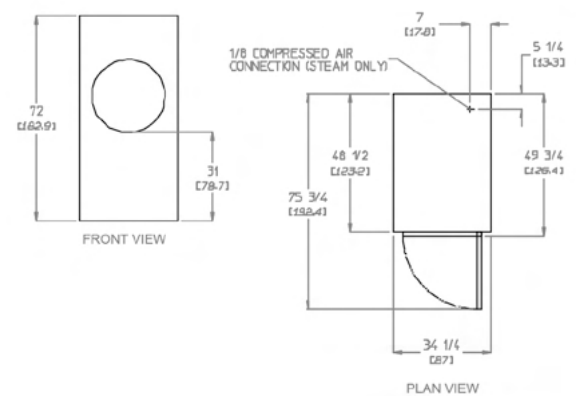
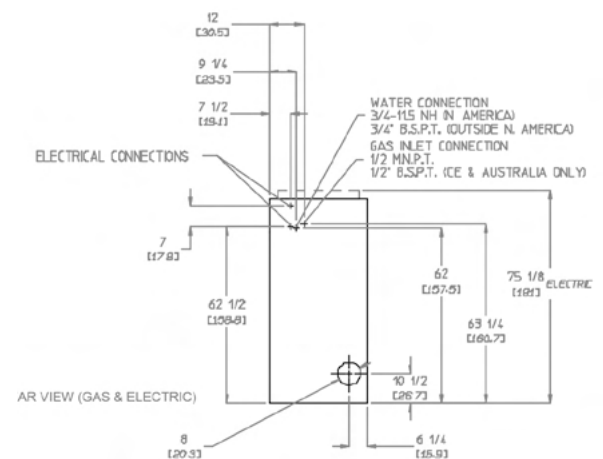
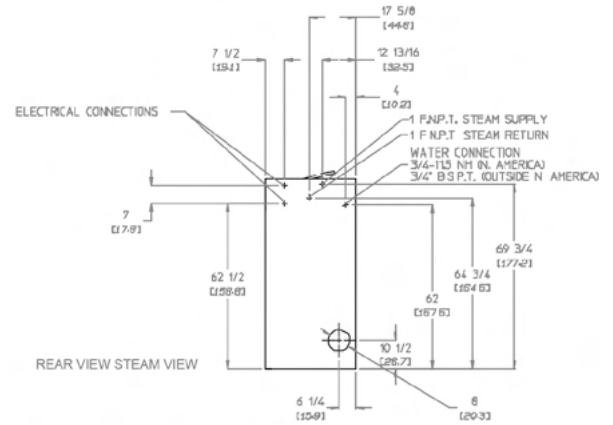

Specifications in parentheses are metric equivalents.

\* Reversing dryers use 3-phase (3Ø) motors.

\*\* Size of piping to dryer varies with installation conditions. Contact factory for assistance.

\*\*\* Specify air-operated or electromechanical steam damper system.

Air-operated steam damper system must be provided with clean, dry, and regulated 80 psi +/- 10 psi (5.51 bar +/- 0.69