



PRIMUS FX LINE WASHING MACHINES



MODELS:

FX180
FX240
FX280

DIMENSIONS:

HxWxD: 1410x970x970mm
HxWxD: 1410x970x1105mm
HxWxD: 1410x970x1185mm

CAPACITY:

20kg
27kg
32kg

IDEAL FOR:

	INDUSTRIAL	HOSPITALITY	HEALTHCARE	ANIMAL CARE	EDUCATION	PUBLIC SECTOR	VENDED LAUNDRY
FX180	✓	✓	✓			✓	
FX240	✓	✓	✓			✓	
FX280	✓	✓	✓				

FEATURES:

- ▶ Freestanding, high spin (up to 1047 rpm - FX180)
- ▶ 460 G extraction speed (FX180, FX240)
- ▶ Cascade Drum
- ▶ Stainless steel drum and tub
- ▶ Patented soap hopper
- ▶ Large drain valve (Ø 76 mm)
- ▶ Easy access to all vital parts from the front
- ▶ Large door opening for easy loading & unloading

OPTIONS:

- ▶ Prep for coin and Central Pay
- ▶ Anthracite grey painted panels
- ▶ Stainless steel front and side panels
- ▶ Weighing System
- ▶ USB + RS485 plug
- ▶ Liquid soap connection
- ▶ Liquid soap pumps
- ▶ Steam heating version
- ▶ ECO version: lower kW rating on request
- ▶ 3rd water inlet

CONTROL:

- ▶ XControl FLEX (VEND) - fully programmable and customisable cycles
 - User-friendly screen with operating instructions built in as part of the control
 - Complete control content available in 34 languages
- ▶ XControl FLEX PLUS (OPL)
 - User-friendly screen with operating instructions built in as part of the control

ONECARE^{OC} This machine is eligible for our all inclusive service solution, One Care.

FX LINE SPECIFICATIONS	FX180	FX240	FX280
Innerdrum			
Capacity 1:09	20 kg / 44lbs	27 kg / 60lbs	31 kg / 68 lbs
Capacity 1:10	18 kg / 40lbs	24 kg / 53lbs	28 kg / 62 lbs
Volume	180l	240l	280l
Diameter	750mm	750mm	750mm
Drum speed			
Wash	42 rpm	42 rpm	42 rpm
Extraction	1047 rpm	1035 rpm	975 rpm
G-Factor	460	460	400
Heating			
Electricity very low-low-std-higher-special 1 v-2-3	----std 12-higher 18-----	---low 12a- std 18-----	----std 21,9-----
Steam	1 - 8 bar	1 - 8 bar	1 - 8 bar
Hot water	90 °C	90 °C	90 °C
Sound pressure level	≤65 dB (A)	≤65 dB (A)	≤65 dB (A)
Water valves connection	3/4" BSP	3/4" BSP	3/4" BSP
Water pressure	100 - 800 kPa	100 - 800 kPa	100 - 800 kPa
Rec. water pressure	300 - 500 kPa	300 - 500 kPa	300 - 500 kPa
Water inlet	20 l/min	20 l/min	20 l/min
Drain valve	76 outer Ø mm	76 outer Ø mm	76 outer Ø mm
Flow amount with drain valve	210 l/min	210 l/min	210 l/min
Steam valve connection	1/2" BSP	1/2" BSP	1/2" BSP
Steam pressure	100 - 800 kPa	100 - 800 kPa	100 - 800 kPa
Transport Data			
Packed HxWxD	1550x1025x1015mm	1550x1025x1150mm	1550x1025x1225
Gross weight	395 kg	450 kg	515 kg

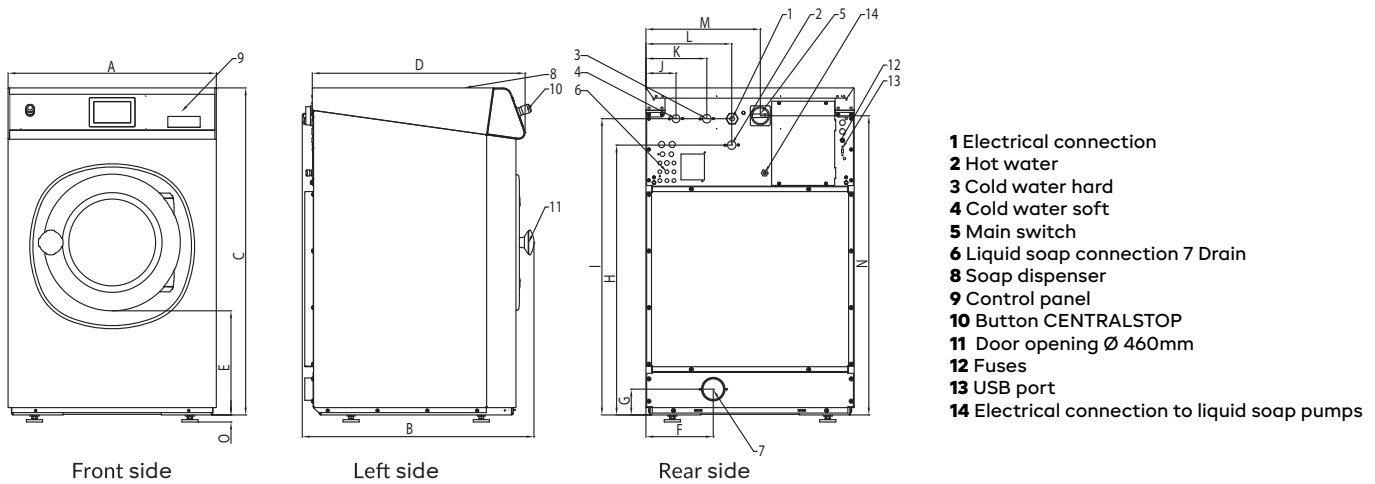

DIMENSIONS

	A	B	C	D	E	F	G	H	I	J	K	L	M	N	O
FX180	970	970	1430	906	477	270	108.5	1215	1297.5	102.5	208	293	610	1315	24
FX240	970	1105	1430	1041	477	270	108.5	1215	1297.5	102.5	208	293	610	1315	24
FX280	970	1185	1430	1116	477	270	108.5	1215	1305	102.5	208	293	610	1315	24
	width	depth	height												