



PRIMUS FX LINE WASHING MACHINES



MODELS:

RX180
RX240
RX280

DIMENSIONS:

HxWxD: 1410x890x915mm
HxWxD: 1410x890x1060mm
HxWxD: 1410x890x1135mm

CAPACITY:

20kg
27kg
31kg

IDEAL FOR:



ANIMAL CARE



INDUSTRIAL



VENDED LAUNDRY

FEATURES:

- ▶ Rigid mounted, normal spin, 100G factor
- ▶ Stainless steel drum and tub
- ▶ Patented soap hopper
- ▶ High capacity water inlets (RX280)
- ▶ Large drain valve (Ø 76 mm)
- ▶ Easy access to all vital parts from the front
- ▶ Large door opening for easy loading & unloading

OPTIONS:

- ▶ 200G factor execution
- ▶ XControl - Fully programmable
- ▶ Anthracite grey painted panels
- ▶ Stainless steel front and side panels
- ▶ USB plug (on the back panel)
- ▶ Prep for coin and Central Pay
- ▶ Liquid soap connection
- ▶ Liquid soap pumps
- ▶ Steam heating version
- ▶ High capacity water inlets (RX180, RX240)
- ▶ ECO version : lower kW rating on request
- ▶ 3rd water inlet

CONTROL:

- ▶ XControl FLEX (VEND) - fully programmable and customisable cycles
 - User-friendly screen with operating instructions built in as part of the control
 - Complete control content available in 34 languages
- ▶ XControl FLEX PLUS (OPL)
 - User-friendly screen with operating instructions built in as part of the control

ONECARE^{OC} This machine is eligible for our all inclusive service solution, One Care.

RX LINE SPECIFICATIONS	RX180	RX240	RX280
Innerdrum			
Capacity 1:09	20 kg / 44lbs	27 kg / 60lbs	31 kg / 68 lbs
Capacity: 1:10	18 kg / 40lbs	24 kg / 53lbs	28 kg / 62 lbs
Volume	180l	240l	280l
Diameter	750mm	750mm	750mm
Drum speed			
Wash	42 rpm	42 rpm	42 rpm
Extraction	490 rpm (690*)	490 rpm (690*)	490 rpm (690*)
G-Factor	100 (200*)	100 (200*)	100 (200*)
Heating			
Electricity very low-low-std-higher-special 1 v-2-3	----std 12-higher 18-----	---low 12a- std 18-----	----std 21,9-----
Steam	1 - 8 bar	1 - 8 bar	1 - 8 bar
Hot water	90 °C	90 °C	90 °C
Sound pressure level	≤65 dB (A)	≤65 dB (A)	≤65 dB (A)
Water valves connection	3/4" BSP	3/4" BSP	3/4" BSP
Water pressure	100 - 800 kPa	100 - 800 kPa	100 - 800 kPa
Rec. water pressure	300 - 500 kPa	300 - 500 kPa	300 - 500 kPa
Water inlet	20 l/min	20 l/min	20 l/min
Drain valve	76 outer Ø mm	76 outer Ø mm	76 outer Ø mm
Flow amount with drain valve	210 l/min	210 l/min	210 l/min
Steam valve connection	1/2" BSP	1/2" BSP	1/2" BSP
Steam pressure	100 - 800 kPa	100 - 800 kPa	100 - 800 kPa
Transport Data			
Packed HxWxD	1550x925x970mm	1550x925x1130mm	1550x925x1190mm
Gross weight	270kg (335)*	290kg (355)*	305kg (385)*

*200 G-factor execution

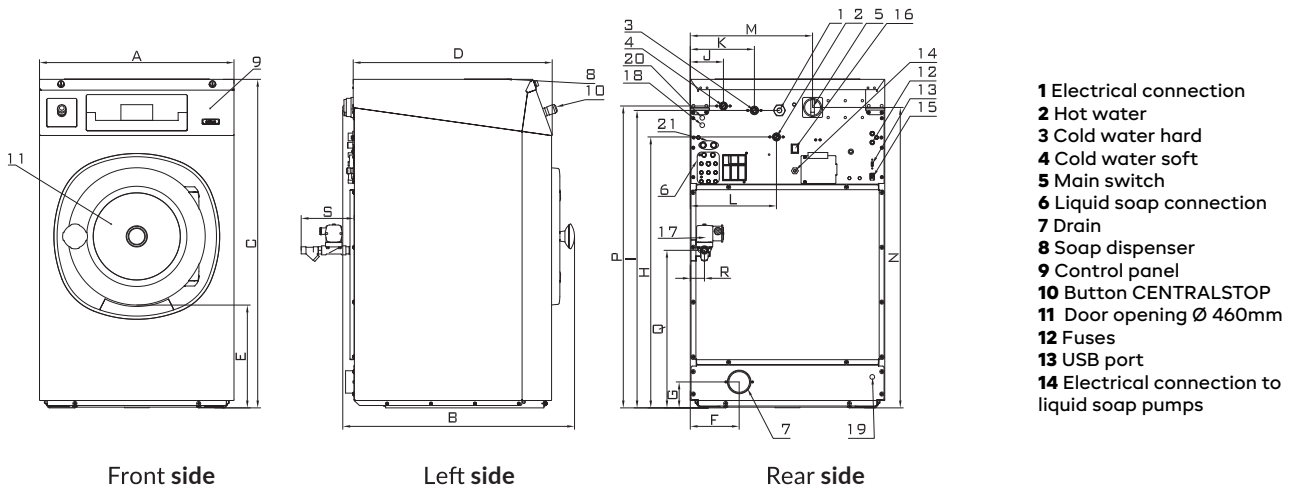

DIMENSIONS

	A	B	C	D	E	F	G	H	I	J	K	L	M	N	P	Q	R	S
RX180	890	915	1410	815	465	280	130	1212	1297	113	218	303	625	1270	1317	528	54	120
RX240	890	1060	1410	960	465	280	130	1212	1297	113	218	303	625	1270	1317	528	54	120
RX280	890	1135	1410	1035	465	280	130	1212	1297	113	218	303	625	1270	1317	528	54	120
	width	depth	height															