



SCHULTHESS PROLINE W-SERIES



MODELS:

W80
W100
W130
W160





DIMENSIONS:

HxWxD: 1210x969x820mm
HxWxD: 1210x696x915mm
HxWxD: 1360x790x935mm
HxWxD: 1360x790x1035mm

CAPACITY:

9kg
11kg
14kg
18kg

IDEAL FOR:

	 INDUSTRIAL	 HOSPITALITY	 HEALTHCARE	 ANIMAL CARE	 EDUCATION	 PUBLIC SECTOR	 VENDED LAUNDRY
W80	✓	✓	✓	✓	✓	✓	✓
W100	✓	✓					
W130		✓	✓				
W160	✓	✓	✓				

FEATURES:

- ▶ Freestanding, high-speed
- ▶ Stainless steel drum and outer drum
- ▶ Intuitive operation with 4.3-inch colour display
- ▶ Control system «Expert»
- ▶ Ergonomic detergent dispenser
- ▶ Laundry trap protection
- ▶ Convenient loading/unloading through large door

- ▶ Hot water connection
- ▶ Drain valve
- ▶ Time preselection up to 7 weekdays
- ▶ Up to 24 languages
- ▶ Autoclean (Models W130, W160)
- ▶ Connection for 8 liquid detergent dosing pumps (Models W80, W100)

OPTIONS:

- ▶ Control system «Expert+»
- ▶ Stainless steel housing
- ▶ USB interface
- ▶ Machine plinth 280mm/270mm
- ▶ Plinth with lint filter drawer
- ▶ Drain pump
- ▶ Hygiene monitoring via USB
- ▶ PrePaid Card System (RFID) (Models W130, W160)

ONECARE^{cc} This machine is eligible for our all inclusive service solution, One Care.

**service
Master** 

This machine is compatible with our smart laundry solution, serviceMaster

SCHULTHESS PROLINE	W80	W100	W130	W160
Product number	4202.1	4203.1	4204.1	4205.1
Properties				
Fill ratio (1:9)	9kg	11kg	14kg	18kg
Filling quantity (1:10)	8kg	10kg	13kg	16kg
Drum volume	80l	100l	130l	160l
Drum opening diameter	355 Ø mm	355 Ø mm	450 Ø mm	450 Ø mm
Drum diameter	517mm	517mm	620mm	620mm
Drum depth	372 min	464 min	427 min	527 min
Spin speed	1200 rpm	1200 rpm	1100 rpm	1100 rpm
G-factor	416	416	419	419
Residual moisture	46%	46%	48%	48%
Programme duration cold water connection ²	55 minutes	57 minutes	55 minutes	55 minutes
Programme duration hot water connection 70°C ²	47 minutes	48 minutes	46 minutes	46 minutes
Energy consumption ^{3/4)}	1.5 / 0.42 kWh	1.7 / 0.42 kWh	2.4 / 0.45 kWh	3.1 / 0.45 kWh
Water consumption ²	67l	90l	112l	144l
Electrical Requirements				
Supply voltage (V)	400 3N~ / 50 Hz	400 3N~ / 50 Hz	400 3N~ / 50 Hz	400 3N~ / 50 Hz
Connected load	10 kW	10 kW	14.9 kW	18.0 kW
Electric heating	9.0 kW	9.0 kW	14.5 kW	17.6 kW
Drive	1.0 kW	1.0 kW	1.5 kW	1.5 kW
Protection	16 A	16 A	25 A	32 A
Plumbing Requirements				
Water pressure on site	0.15 –1.0 MPa	0.15 –1.0 MPa	0.15 –1.0 MPa	0.15 –1.0 MPa
Cold water hard inflow ¾-inc h	>13 litre/min	>13 litre/min	>13 litre/min	>13 litre/min
Hot water supply from central boiler max. 70°C ¾-inch	>13 litre/min	>13 litre/min	>13 litre/min	>13 litre/min
Drain quantity drain valve Ø 50 mm / Ø 75 mm	260 litre/min	260 litre/min	260 litre/min	260 litre/min
Drain pump diameter 22 mm	32 litre/min	32 litre/min	-	-

Explanations:

- not available

• available

²⁾Cotton 60°C without pre-wash

³⁾Cotton 60°C prg. cold water

⁴⁾Cotton 60°C prg. hot water 70°C

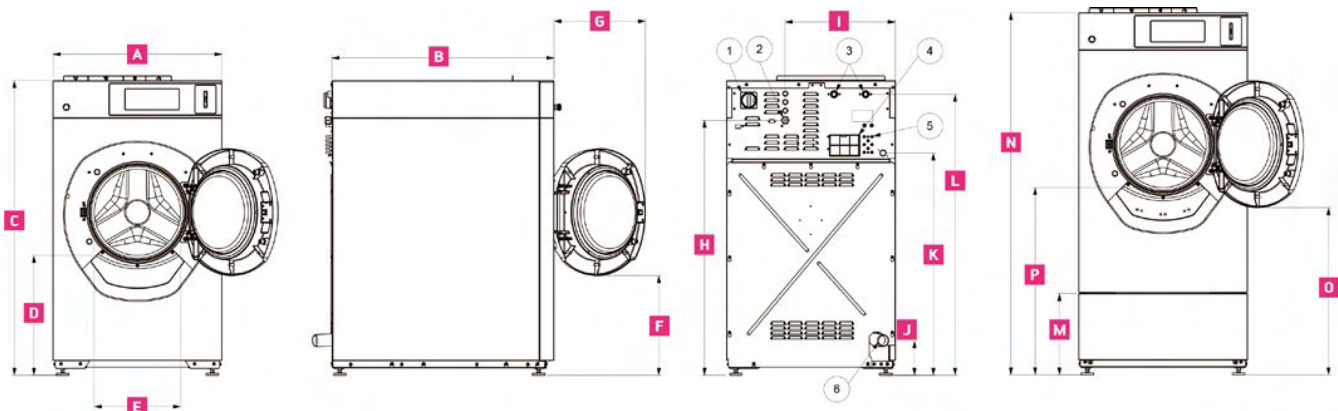

	A	B	C	D	E	F	G	H	I	J	K	L	M	N	O	P	Weight
W80	696	820	1210	500	355	355	380	1050	455	150	915	1160	330	1490	690	780	210
W100	696	915	1210	500	355	355	380	1050	455	150	915	1160	330	1490	690	780	220
W130	790	935	1360	530	450	450	-	1200	590	150	-	1300	330	1630	720	800	350
W160	790	1035	1360	530	450	450	-	1200	590	150	-	1300	330	1630	720	800	365

1 Main switch 2 Electrical connection 3 Water connection 4 Overflow / Venting 5 Connection for liquid detergent 6 Drain pipe