



Pulpmatic Ultima Waste Height

Range between:-

- 250 mm Maximum
- 200 mm Nominal
- 180 mm Minimum

to centre of pipe

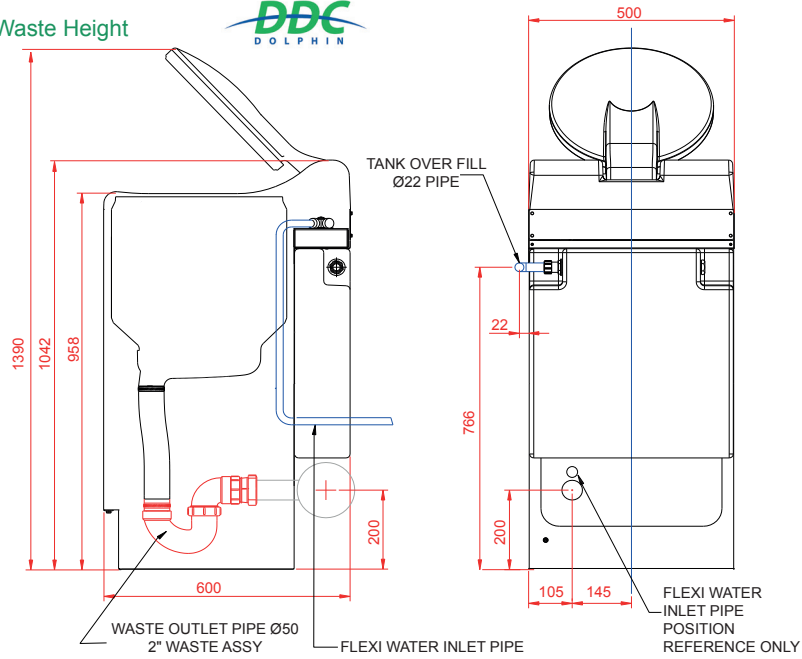

Pulpmatic Ultima : Product Data

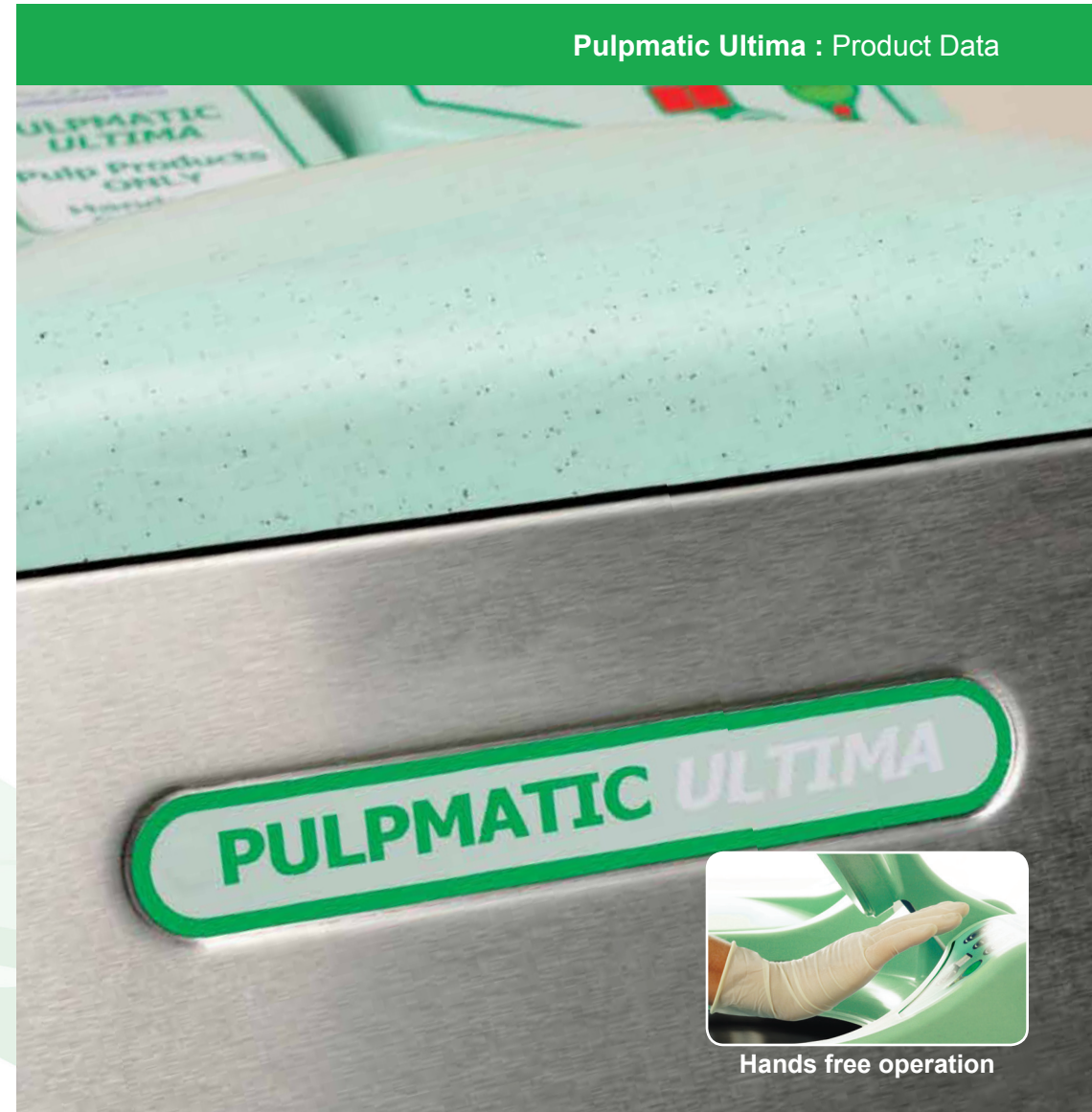

DDC Dolphin Ltd
 The Fulcrum, Vantage Way, Poole, Dorset BH12 4NU
 tel: +44 (0) 1202 731555 | fax: +44 (0) 1202 731666
 info@ddcdolphin.co.uk

www.ddcdolphin.co.uk

DDC Dolphin, Pulpmatic, Panamatic, Incomatic, Hygenex, MicrobeSafe are Registered Trademarks

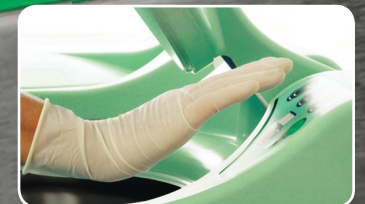

Hands free operation

The Pulpmatic Ultima

Modern and hygienic disposal of medical pulp for high use areas

The Pulpmatic Ultima is a large capacity pulp macerator able to cope with 4-6 pulp items per 120 second cycle. Suitable for busy dirty utility rooms the Pulpmatic Ultima was developed to cope in high use areas and its unique nine bladed macerating technology was specially developed for the Pulpmatic, allowing for rapid cycle time and low noise levels.

The Unique Hands Free Operation - The Pulpmatic Ultima uses our unique totally hands free technology offering completely hands free operation by means of a foot cup at the base of the machine and an optical sensor to close and start the machine. This makes it not only more convenient, but also more hygienic to use than other macerators and greatly reduces the potential for cross contamination.

Efficient and Economical - The Pulpmatic Ultima is designed to give excellent efficiency. By using a nine blade cutting disc pulp products are rapidly and quietly disposed of allowing you to keep up with the high work loads in busy environments.

The quick cycle time reduces staff waiting time and water and electrical consumption which in turn translates into reduced running costs.

Automatic disinfection - The automatic disinfection dosing option will cleanse the drum after each cycle to meet EN1276 and EN13704 standards eliminating spores of up to 99.999% of major HCAI's.

Easy service programme – Service support is provided by our own specialist and highly skilled engineers and we offer a choice of fully comprehensive service contracts focused on individual customer needs.



MicrobeSafe
Antimicrobial Surface

Key Features

Unique hands free open and close operation

Dual antimicrobial action

Large capacity

Efficient and economical

Environmentally friendly

Automatic disinfection

Easy to use

Easy to install

Easy service programme

Due to a policy of continuous development and improvement the right is reserved to supply products which may differ slightly from those described in this brochure

General	
Stainless Steel grade:	304
Dimensions: w x h x d	500 x 1042 x 600 mm
Weight:	Dry 85kg
Capacity:	4-6 pieces medical pulp
Operation cycle time:	120 seconds
Decibel rating:	59.5 dba
Electrical	
Voltage: 110V	60Hz dedicated 15A breaker (UL version)
Voltage: 230V	50Hz dedicated 13A breaker
Voltage:230V	60Hz dedicated 13A breaker
Voltage: 415V	50Hz 3Ph + Neutral & Earth 16A
Cable connection: 230V	3 core sheathed x 1.5mm ² , 2m long
Cable connection: 415V	5 core sheathed x 1.5mm ² , 2m long
Circuit Protection:	30mA RCD, GFI, IEC60364 compliant
Rated power input:	1.1kW
Electrical consumption per cycle:	0.02kW
Steam generator power:	N/A
Motor power:	0.75kW
Pump power:	0.345kW
Water	
Water connection:	¼" BSP male fittings required
Water pressure:	Cold water ¼" 0.5-10 bar
Water flow rate (Min):	12 Litres per minute at 1 bar
Water tank capacity:	24 Litres
Water consumption per cycle:	26 Litres
Waste connection:	N.B. 50mm (2")
Overflow connection:	22mm
Disinfection	
Recommended disinfection detergents:	EcoCleanse+
Disinfection tank volume: (external)	5 Litres
Disinfection dosing per cycle:	8 Millilitres